



TECHNICAL DOCUMENTATION

Professional network solutions for enterprise, industrial and OT/IT environments.

Provided by 4net in collaboration with leading technology partners.

4net

Reliable OT/IT network infrastructure solutions

 fournet.be

 info@fournet.be

 +32 (0)15 29 29 99



Trusted expertise for reliable networks.



The new generation of **RMA** cabinets

NEW

Welded cabinet with removable side panels
and rear cover, IP20, capacity 800 kg

The new generation of RMA cabinets uses innovative features in the skeleton construction which allow for an increased load capacity of 800kg for all sizes, all while maintaining structural rigidity.

- ❶ The roof of the 600mm wide cabinet is made of a single piece of material, including newly profiled sliding rails.
- ❷ The vertical rails have a new shape, are wider, and are made of 1,3mm thick material.
- ❸ The lower part of the skeleton has been modified and contributes to the increased load capacity.



■ Flexible door opening

The hinge system allows the door to open almost 180°. The door can be easily removed and re-mounted to change the direction of opening.



■ Bonding

All detachable parts are bonded in compliance with the relevant standards.



■ New skeleton rails

Increased load capacity and the possibility of installing accessories.



■ Flex frame

(for 800mm wide cabinets) This system allows for vertical rail installation in 19", 21" and 23" spans according to the specific needs of equipment in use.



■ Triton handles

We manufacture our own handles for the free-standing cabinets. By replacing the plastic module (not included), a traditional or half-cylindrical lock insert can be used. PATENT: PUV 2013-27443



Removable sides and back cover. The RMA cabinet features a welded skeleton with removable side panels and a back cover. These, as well as the rear cover, are secured to the skeleton with locks which typically use a common key.



■ Detail of the cabinet removable rear cover locking latch



■ Detail of the removable side panel lock

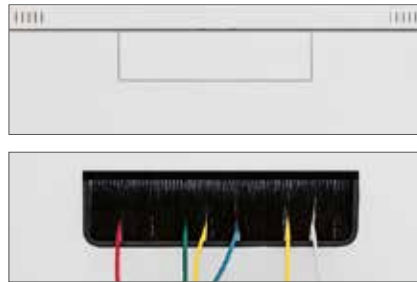

■ **Break-out blanking panels**
Cable entry openings in the rear part of the cabinet are covered with breakout-type blanking panels. To prevent dust penetration, cables can be sealed in the opening with a brush. The fringe edge protects the cables from damage. (both are included as part of the cabinet's supply)



RMA 800 x 800 mm

The 800 mm wide RMA cabinet uses non-integrated sliding rails.



■ **Opening for a fan unit**
The fan unit opening is covered by a breakout cover. This allows for the installation of a ventilation system. The appropriate fan unit, according to the cabinet dimensions, is detailed on pages 8 and 10.



■ **Skeleton perforation**
The RMA cabinet has a perforated skeleton to ensure access of cooling air to the equipment inside. The installation of fan units can further generate cool air.



■ **Castors, levelling feet**
Left picture shows preparation for mounting castors or levelling feet. On the right installed levelling feet. The levelling feet are included in the RMA cabinet package.



Type	Dimensions (mm)	Maximum recommended load (kg)
RAX-PO-X66-XD	600 x 600	1900
RAX-PO-X68-XD	600 x 800	1900
RAX-PO-X69-XD	600 x 900	1900
RAX-PO-X61-XD	600 x 1000	1900
RAX-PO-X60-XD	600 x 1100	1900
RAX-PO-X62-XD	600 x 1200	1900
RAX-PO-X86-XD	800 x 600	1900
RAX-PO-X88-XD	800 x 800	1900
RAX-PO-X89-XD	800 x 900	1900
RAX-PO-X81-XD	800 x 1000	1900
RAX-PO-X80-XD	800 x 1100	1900
RAX-PO-X82-XD	800 x 1200	1900

■ RAB-PO-Xxx-XD, RAC-PO-Xxx-XD

The base is fully universal, which means that it is usable for all types of free-standing cabinets except RSX. The construction of the base is formed of two side profiles which correspond to the depth of the cabinet, and two cover panels (front and back) with a corresponding width. Bases XD series have a load capacity 1900 kg.

Supply includes

- 2x side base profile with a cable entry (with breakout-type blanking panels)
- 2x cover with cable openings (with breakout-type blanking panels)
- 1x cover with a filter
- 1x anti-dust brush
- 4x Screw M10 x 30
- 4x Washer 10,5
- 8x Screw M5 x 30

The bases are delivered dismantled. The second dust filter for the second cover replacing can be easily ordered later. The base always exactly copies the ground plan of the cabinet regardless of installation of filter. The bases are standardly supplied in widths of 600 and 800 mm and depths from 600 to 1200 mm. All the bases are 120 mm high.

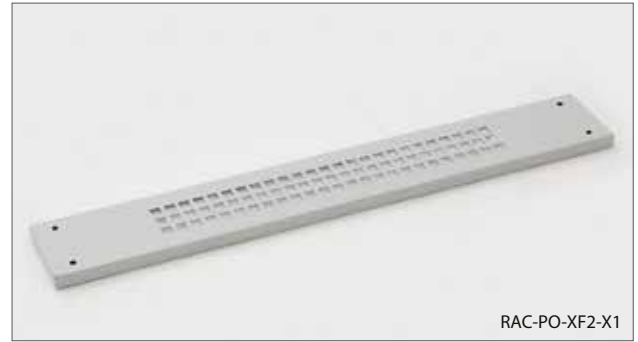

Type	Dimensions - w * h (mm)
RAX-PO-XF1-X1	600 x 120
RAX-PO-XF2-X1	800 x 120

■ RAB-PO-XFx-X1, RAC-PO-XFx-X1

Filter for bases.

Supply

Screw M5 x 30 4x



■ RAB-SS-X01-X1, RAC-SS-X01-X1

Stabilizers for free-standing cabinets.

Supply

Screw M5 x 12 4x



Cabinet depth (mm)	Cabinet width (mm)	
	600	800
600	RAX-VP-X77-X1	RAX-VP-X83-X1
800	RAX-VP-X78-X1	RAX-VP-X84-X1
900	RAX-VP-X79-X1	RAX-VP-X85-X1
1000	RAX-VP-X80-X1	RAX-VP-X86-X1
1100	RAX-VP-X81-X1	RAX-VP-X87-X1
1200	RAX-VP-X82-X1	RAX-VP-X88-X1

■ RAX-VP-Xxx-X1

Installation cable management bar for RMA, RZA, RTA, RYA, RDA.

STOP For the correct use of the optional Accessories the following instructions are important:

- install the cabinet on a level and sufficiently firm floor
- place at least 65% of the load in the the lower half of the height of the cabinet
- ensure that the load is evenly distributed between the front and rear vertical rails
- when taxiing with a loaded cabinet, comply with the relevant standards.

Calculation of the load capacity of one wheel:

**Total weight of the cabinet (i.e. own weight + installed accessories) / 3 = load capacity of one castor.*

The load capacities of the castors are applicable for travel speed up to 4 km/h on level ground and smooth surface at ambient temperature in the range of 10-30 °C.

All dimensions, load capacities and tolerances correspond to following standards: EN 12527-12533, DIN 7845.



RAX-MS-X81-X1

Direct mounting castors set.

Max. recommended load capacity*:

- **200 kg** for type **RMA**, RZA 600 mm wide,
 - **400 kg** for type **RMA**, RZA 800 mm wide.
- The height of the cabinet is increased by 111 mm.

Set

- Castors with a brake 2x
- Castors without a brake 2x
- Screw M5 x 20 Thorx 16x
- Flat washer 5,3..... 16x



Cabinet depth (mm)	Cabinet width (mm)	
	600	800
600	RAX-RK-X66-X1	RAX-RK-X86-X1
800	RAX-RK-X68-X1	RAX-RK-X88-X1
900	RAX-RK-X69-X1	RAX-RK-X89-X1
1000	RAX-RK-X61-X1	RAX-RK-X81-X1
1100	RAX-RK-X60-X1	RAX-RK-X80-X1
1200	RAX-RK-X62-X1	RAX-RK-X82-X1

RAX-RK-Xxx-X1

Castors with reinforcing fram

Castors with reinforcing frame for **RMA**, RZA type enclosures. Must be ordered according to the floor plan of the cabinet.

Max. recommended load capacity*:

- **450 kg** for type **RMA**, RZA,.
- The height of the cabinet is increased by 111 mm.

Set

- Castors with a brake 2x
- Castors without a brake 2x
- Screw M5 x 12 Thorx 16x
- Screw M5 x 20 Thorx 16x
- Flat washer 5,3 16x
- U-profile 4x

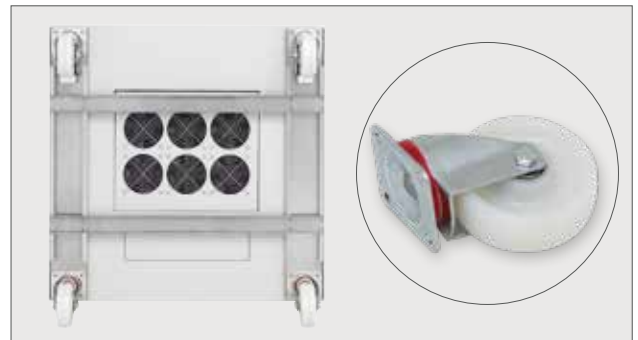

Cabinet depth (mm)	Cabinet width (mm)	
	600	800
600	RAX-RK-D66-X1	RAX-RK-D86-X1
800	RAX-RK-D68-X1	RAX-RK-D88-X1
900	RAX-RK-D69-X1	RAX-RK-D89-X1
1000	RAX-RK-D61-X1	RAX-RK-D81-X1
1100	RAX-RK-D60-X1	RAX-RK-D80-X1
1200	RAX-RK-D62-X1	RAX-RK-D82-X1

RAX-RK-Dxx-X1

Castors with reinforcing fram

Castors with reinforcing frame for **RMA**, RZA, RTA, RYA, RDA, RDE type enclosures. Must be ordered according to the floor plan of the cabinet.

Max. recommended load capacity*:

- **900 kg** for type **RMA**, RZA,
 - **1050 kg** for type RTA, RYA, RDA, RDE.
- The height of the cabinet is increased by 158 mm.

Set

- Castors with a brake 2x
- Castors without a brake 2x
- Screw M5 x 12 Thorx 16x
- Screw M5 x 20 Thorx 16x
- Flat washer 5,3 16x
- U-profile 4x

Swing frame

■ All 800 mm wide Triton cabinets can be equipped with a swing frame for mounting devices that require rear access. The swing frame reduces the usable height of the cabinet by 5U and can support up to 150 kg. The frame has two locks for securing it when closed. The distance of the swing frame from the cabinet doors

can be smoothly adjusted. The position of the frame affects the maximum usable depth of the mounted devices. When mounted in the optimal position, it can accommodate a 19" device with a depth of up to 300 mm. The swing frame can be mounted simultaneously with 19" verticals.

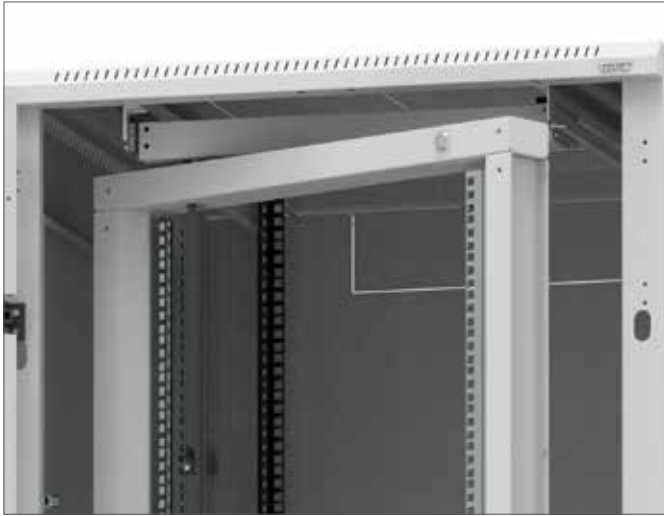

Swing frame	Cabinet height (U)	B (U) Usable frame height
RAC-VM-A17-A1	22	17
RAC-VM-A22-A1	27	22
RAC-VM-A27-A1	32	27
RAC-VM-A32-A1	37	32
RAC-VM-A37-A1	42	37
RAC-VM-A40-A1	45	40
RAC-VM-A42-A1	47	42

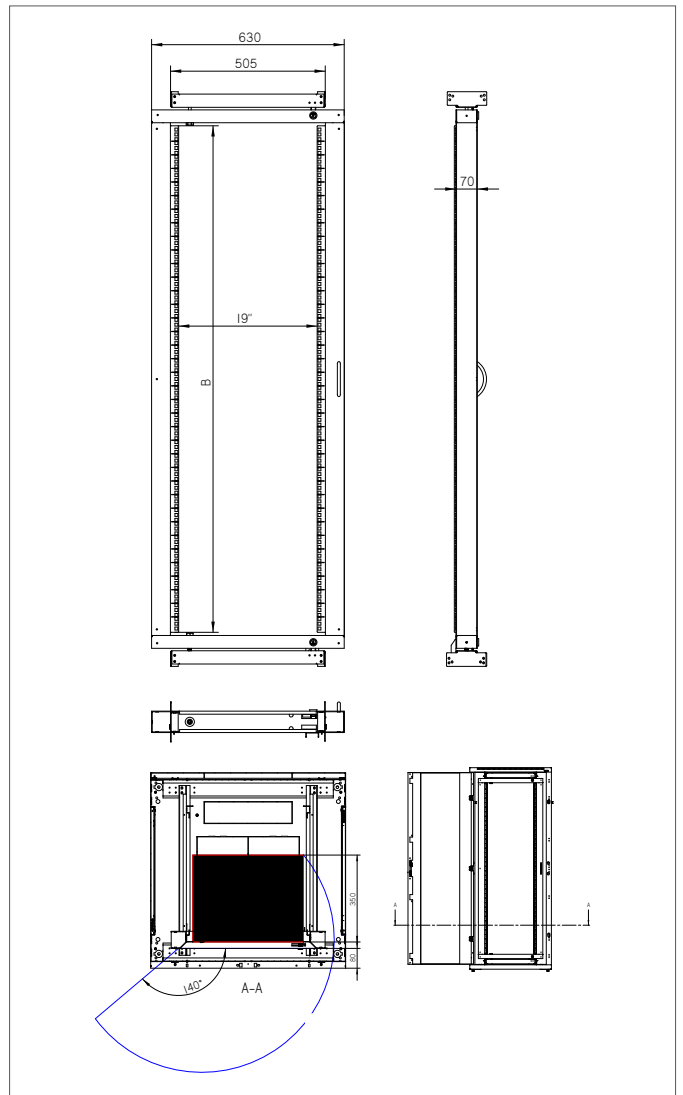

■ Door for fan units

With this cabinet type, it is possible to order a special metal door ready for mounting RAC-CH-X0x-X3 fan units. More information can be found at www.triton-racks.com in the Active Cooling section.

RMA 600 x 600								
Type	A	B	C	D	E	Weight gross (kg)	Weight net (kg)	Maximum recommended load (with legs or base)
	(mm)							
RMA-15-A66-CAX-N1	770	668	497	600	600	43,3	34,7	800 kg
RMA-18-A66-CAX-N1	900	798	497	600	600	47,5	39,0	
RMA-22-A66-CAX-N1	1080	978	497	600	600	53,0	44,4	
RMA-27-A66-CAX-N1	1300	1198	497	600	600	60,2	51,4	
RMA-32-A66-CAX-N1	1525	1423	497	600	600	67,4	58,6	
RMA-37-A66-CAX-N1	1750	1648	497	600	600	74,7	65,8	
RMA-42-A66-CAX-N1	1970	1868	497	600	600	81,7	72,7	
RMA-45-A66-CAX-N1	2105	2003	497	600	600	86,0	77,0	
RMA-47-A66-CAX-N1	2194	2092	497	600	600	88,7	79,7	

RMA 600 x 800								
Type	A	B	C	D	E	Weight gross (kg)	Weight net (kg)	Maximum recommended load (with legs or base)
	(mm)							
RMA-15-A68-CAX-N1	770	668	497	600	800	49,6	39,9	800 kg
RMA-18-A68-CAX-N1	900	798	497	600	800	54,3	44,5	
RMA-22-A68-CAX-N1	1080	978	497	600	800	60,4	50,6	
RMA-27-A68-CAX-N1	1300	1198	497	600	800	68,2	58,2	
RMA-32-A68-CAX-N1	1525	1423	497	600	800	76,1	66,1	
RMA-37-A68-CAX-N1	1750	1648	497	600	800	84,3	74,1	
RMA-42-A68-CAX-N1	1970	1868	497	600	800	92,0	81,8	
RMA-45-A68-CAX-N1	2105	2003	497	600	800	96,7	86,5	
RMA-47-A68-CAX-N1	2194	2092	497	600	800	99,7	89,5	

RMA 600 x 900								
Type	A	B	C	D	E	Weight gross (kg)	Weight net (kg)	Maximum recommended load (with legs or base)
	(mm)							
RMA-15-A69-CAX-N1	770	668	497	600	900	54,4	44,0	800 kg
RMA-18-A69-CAX-N1	900	798	497	600	900	59,4	49,1	
RMA-22-A69-CAX-N1	1080	978	497	600	900	66,2	55,8	
RMA-27-A69-CAX-N1	1300	1198	497	600	900	74,9	64,3	
RMA-32-A69-CAX-N1	1525	1423	497	600	900	83,6	73,0	
RMA-37-A69-CAX-N1	1750	1648	497	600	900	92,6	81,8	
RMA-42-A69-CAX-N1	1970	1868	497	600	900	101,0	90,3	
RMA-45-A69-CAX-N1	2105	2003	497	600	900	106,3	95,5	
RMA-47-A69-CAX-N1	2194	2092	497	600	900	109,7	98,8	

RMA 600 x 1000								
Type	A	B	C	D	E	Weight gross (kg)	Weight net (kg)	Maximum recommended load (with legs or base)
	(mm)							
RMA-15-A61-CAX-N1	770	668	497	600	1000	57,5	46,6	800 kg
RMA-18-A61-CAX-N1	900	798	497	600	1000	62,9	51,9	
RMA-22-A61-CAX-N1	1080	978	497	600	1000	69,9	58,9	
RMA-27-A61-CAX-N1	1300	1198	497	600	1000	78,9	67,8	
RMA-32-A61-CAX-N1	1525	1423	497	600	1000	88,1	76,9	
RMA-37-A61-CAX-N1	1750	1648	497	600	1000	97,4	86,0	
RMA-42-A61-CAX-N1	1970	1868	497	600	1000	106,3	94,9	
RMA-45-A61-CAX-N1	2105	2003	497	600	1000	111,7	100,3	
RMA-47-A61-CAX-N1	2194	2092	497	600	1000	115,2	103,8	

RMA 600 x 1100

Type	A	B	C	D	E	Weight gross (kg)	Weight net (kg)	Maximum recommended load (with legs or base)
RMA-15-A60-CAX-N1	770	668	497	600	1100	61,2	49,5	800 kg
RMA-18-A60-CAX-N1	900	798	497	600	1100	66,4	54,7	
RMA-22-A60-CAX-N1	1080	978	497	600	1100	73,8	62,0	
RMA-27-A60-CAX-N1	1300	1198	497	600	1100	83,1	71,3	
RMA-32-A60-CAX-N1	1525	1423	497	600	1100	92,7	80,7	
RMA-37-A60-CAX-N1	1750	1648	497	600	1100	102,3	90,2	
RMA-42-A60-CAX-N1	1970	1868	497	600	1100	111,6	99,5	
RMA-45-A60-CAX-N1	2105	2003	497	600	1100	117,2	105,1	
RMA-47-A60-CAX-N1	2194	2092	497	600	1100	120,9	108,7	

RMA 600 x 1200

Type	A	B	C	D	E	Weight gross (kg)	Weight net (kg)	Maximum recommended load (with legs or base)
RMA-15-A62-CAX-N1	770	668	497	600	1200	64,1	51,8	800 kg
RMA-18-A62-CAX-N1	900	798	497	600	1200	69,8	57,5	
RMA-22-A62-CAX-N1	1080	978	497	600	1200	77,5	65,1	
RMA-27-A62-CAX-N1	1300	1198	497	600	1200	87,2	74,7	
RMA-32-A62-CAX-N1	1525	1423	497	600	1200	97,1	84,6	
RMA-37-A62-CAX-N1	1750	1648	497	600	1200	107,1	94,5	
RMA-42-A62-CAX-N1	1970	1868	497	600	1200	116,8	104,1	
RMA-45-A62-CAX-N1	2105	2003	497	600	1200	122,6	109,9	
RMA-47-A62-CAX-N1	2194	2092	497	600	1200	126,4	113,7	

Drawing of the roof of a 600 mm wide RMA cabinet.

Suitable fan units RAX-CH-X03/04/05-X3

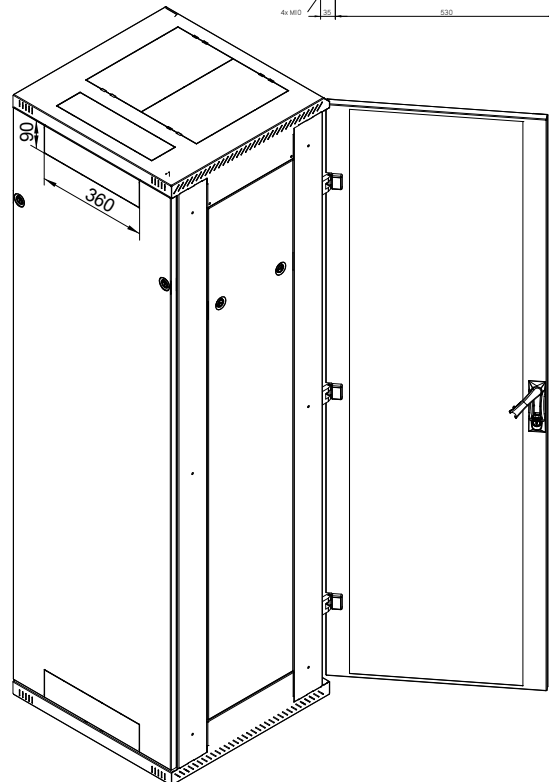
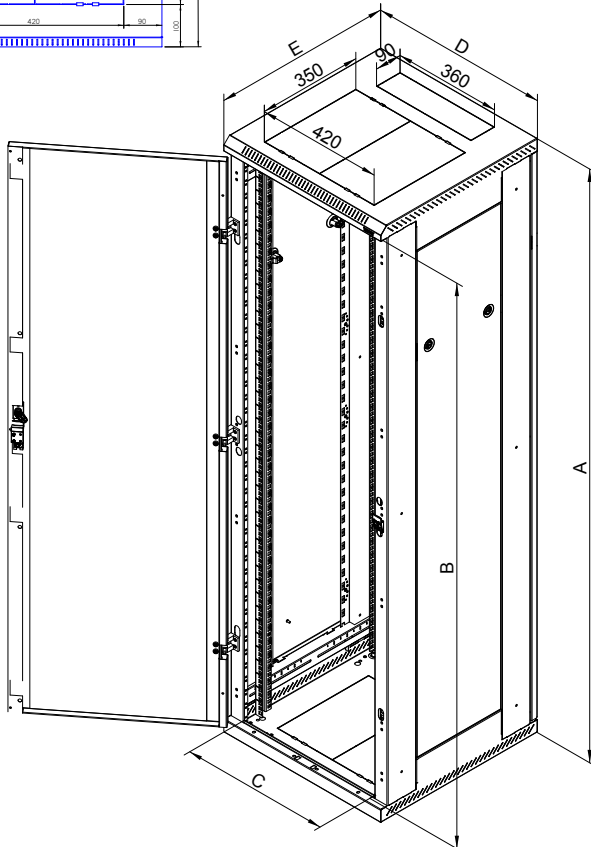
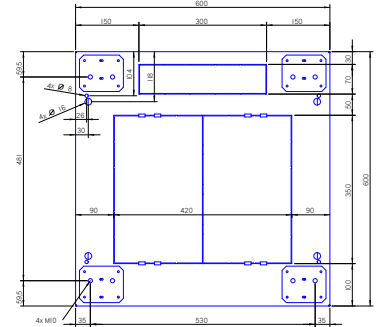
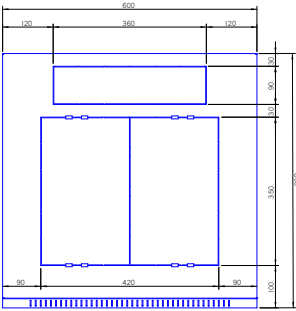

RMA 800 x 600								
Type	A	B	C	D	E	Weight gross (kg)	Weight net (kg)	Maximum recommended load (with legs or base)
	(mm)							
RMA-15-A86-CAX-N1	770	684	697	800	600	56,5	46,5	800 kg
RMA-18-A86-CAX-N1	900	814	697	800	600	61,1	51,1	
RMA-22-A86-CAX-N1	1080	994	697	800	600	67,2	57,2	
RMA-27-A86-CAX-N1	1300	1214	697	800	600	75,1	64,9	
RMA-32-A86-CAX-N1	1525	1438	697	800	600	83,0	72,8	
RMA-37-A86-CAX-N1	1750	1664	697	800	600	91,2	80,7	
RMA-42-A86-CAX-N1	1970	1884	697	800	600	99,0	88,4	
RMA-45-A86-CAX-N1	2105	2019	697	800	600	103,7	93,1	
RMA-47-A86-CAX-N1	2194	2108	697	800	600	106,8	96,1	

RMA 800 x 800								
Type	A	B	C	D	E	Weight gross (kg)	Weight net (kg)	Maximum recommended load (with legs or base)
	(mm)							
RMA-15-A88-CAX-N1	770	684	697	800	800	65,9	54,5	800 kg
RMA-18-A88-CAX-N1	900	814	697	800	800	70,9	59,5	
RMA-22-A88-CAX-N1	1080	994	697	800	800	77,7	66,2	
RMA-27-A88-CAX-N1	1300	1214	697	800	800	86,2	74,6	
RMA-32-A88-CAX-N1	1525	1438	697	800	800	94,9	83,2	
RMA-37-A88-CAX-N1	1750	1664	697	800	800	103,8	91,9	
RMA-42-A88-CAX-N1	1970	1884	697	800	800	112,4	100,3	
RMA-45-A88-CAX-N1	2105	2019	697	800	800	117,5	105,4	
RMA-47-A88-CAX-N1	2194	2108	697	800	800	120,8	108,8	

RMA 800 x 900								
Type	A	B	C	D	E	Weight gross (kg)	Weight net (kg)	Maximum recommended load (with legs or base)
	(mm)							
RMA-15-A89-CAX-N1	770	684	697	800	900	71,8	59,8	800 kg
RMA-18-A89-CAX-N1	900	814	697	800	900	77,4	65,3	
RMA-22-A89-CAX-N1	1080	994	697	800	900	84,7	72,6	
RMA-27-A89-CAX-N1	1300	1214	697	800	900	94,1	81,9	
RMA-32-A89-CAX-N1	1525	1438	697	800	900	103,6	91,3	
RMA-37-A89-CAX-N1	1750	1664	697	800	900	113,3	100,9	
RMA-42-A89-CAX-N1	1970	1884	697	800	900	122,6	110,0	
RMA-45-A89-CAX-N1	2105	2019	697	800	900	128,3	115,7	
RMA-47-A89-CAX-N1	2194	2108	697	800	900	132,0	119,3	

RMA 800 x 1000								
Type	A	B	C	D	E	Weight gross (kg)	Weight net (kg)	Maximum recommended load (with legs or base)
	(mm)							
RMA-15-A81-CAX-N1	770	684	697	800	1000	76,8	63,7	800 kg
RMA-18-A81-CAX-N1	900	814	697	800	1000	82,6	69,4	
RMA-22-A81-CAX-N1	1080	994	697	800	1000	90,2	77,0	
RMA-27-A81-CAX-N1	1300	1214	697	800	1000	100,0	86,6	
RMA-32-A81-CAX-N1	1525	1438	697	800	1000	109,9	96,5	
RMA-37-A81-CAX-N1	1750	1664	697	800	1000	119,9	106,4	
RMA-42-A81-CAX-N1	1970	1884	697	800	1000	129,7	116,0	
RMA-45-A81-CAX-N1	2105	2019	697	800	1000	135,5	121,8	
RMA-47-A81-CAX-N1	2194	2108	697	800	1000	139,4	125,6	

RMA 800 x 1100

Type	A	B	C	D	E	Weight gross (kg)	Weight net (kg)	Maximum recommended load (with legs or base)
RMA-15-A80-CAX-N1	770	684	697	800	1100	81,0	67,8	800 kg
RMA-18-A80-CAX-N1	900	814	697	800	1100	86,6	73,4	
RMA-22-A80-CAX-N1	1080	994	697	800	1100	94,5	81,3	
RMA-27-A80-CAX-N1	1300	1214	697	800	1100	104,6	91,3	
RMA-32-A80-CAX-N1	1525	1438	697	800	1100	114,9	101,5	
RMA-37-A80-CAX-N1	1750	1664	697	800	1100	125,3	111,7	
RMA-42-A80-CAX-N1	1970	1884	697	800	1100	135,5	121,7	
RMA-45-A80-CAX-N1	2105	2019	697	800	1100	141,5	127,7	
RMA-47-A80-CAX-N1	2194	2108	697	800	1100	145,4	131,7	

RMA 800 x 1200

Type	A	B	C	D	E	Weight gross (kg)	Weight net (kg)	Maximum recommended load (with legs or base)
RMA-15-A82-CAX-N1	770	684	697	800	1200	85,2	71,5	800 kg
RMA-18-A82-CAX-N1	900	814	697	800	1200	91,4	77,7	
RMA-22-A82-CAX-N1	1080	994	697	800	1200	99,7	85,9	
RMA-27-A82-CAX-N1	1300	1214	697	800	1200	110,1	96,2	
RMA-32-A82-CAX-N1	1525	1438	697	800	1200	120,8	106,8	
RMA-37-A82-CAX-N1	1750	1664	697	800	1200	131,6	117,4	
RMA-42-A82-CAX-N1	1970	1884	697	800	1200	142,1	127,7	
RMA-45-A82-CAX-N1	2105	2019	697	800	1200	148,3	134,0	
RMA-47-A82-CAX-N1	2194	2108	697	800	1200	152,5	138,1	

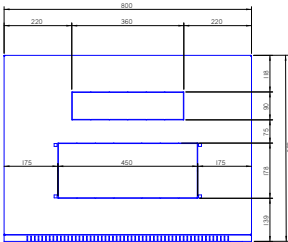

Drawing of the roof of a 800 mm wide RMA cabinet, 600mm deep only.
Suitable fan units RAx-CH-X24/25/26-X1.

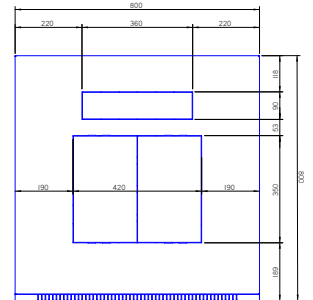

Drawing of the roof of a 800 mm wide RMA cabinet, min. 800mm deep.
Suitable fan units RAx-CH-X03/04/05-X3

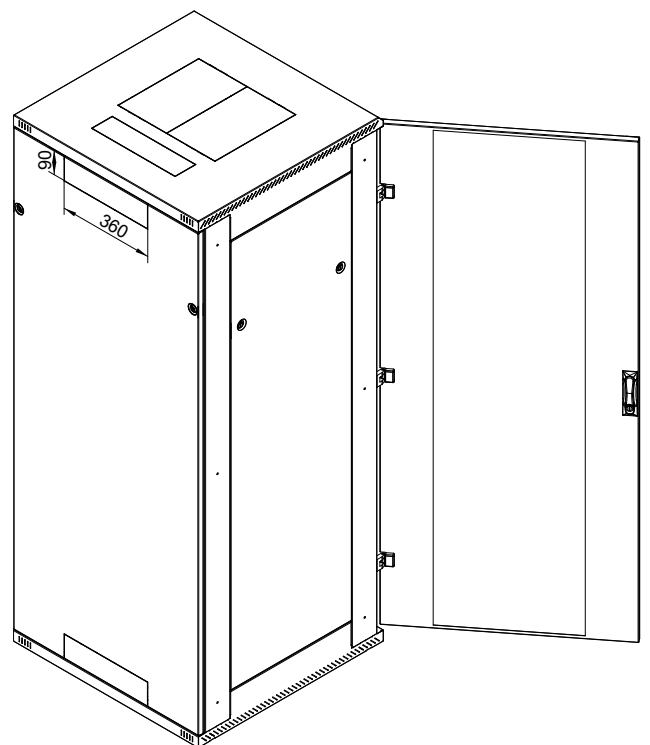
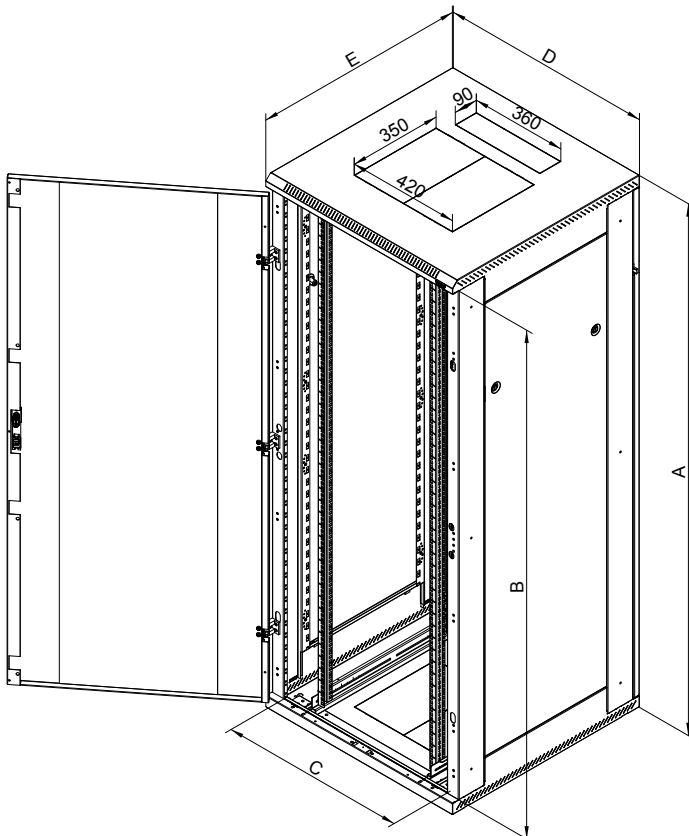

RMA free-standing cabinet

A universal cabinet for data and telecommunication purposes. High capacity for demanding applications, a large selection of sizes and options together with a wide selection of accessories and excellent development make it the best-selling cabinet in our range.

PRODUCT DETAILS

Rigid construction

RMA has a robust welded construction. High quality workmanship and the newest technologies ensure a perfect look of the cabinet. The skeleton rails have a new shape, are wider and made of 1.3 mm thick material.

Flexible door opening

The hinge system allows the door to open 165°. The door can be easily removed and re-mounted to change the direction of opening. The double wing doors are equipped with hook-on hinges.

Tritón handles

We manufacture our own handles for the free-standing cabinets. By replacing the plastic module (not included), a half-cylindrical lock insert can be fitted. Patent: PUV 2013-27443

Adjustable vertical rails

Vertical 19" rails can be adjusted freely in any depth of the cabinet. This simplifies mounting of the device and configuration of cables.

Removable side panels and rear cover

RMA has a welded frame and removable side panels. These are fixed as standard to the frame using a lock with the same key as the door and rear cover.

Door for fan units

With this cabinet type, it is possible to order a special metal door ready for mounting RAX-CH-X0x-X3 fan units. Further information is available in the section Active cooling.

Break-out blanking panels

Entry openings for cables are covered with breakout-type blanking panels. To prevent dust penetration, cables can be sealed in the opening with a brush strip, or simply secure by a protective fringe edge (both supplied with the cabinet).

Opening for a fan unit

A large opening covered with a breakout-type blanking panel enables mounting and removal of the Triton fan unit from the outside of the cabinet without the need of using screws.

Castors, levelling feet, base

The cabinet can be placed on levelling feet (included) or, with optional equipment, on a base, castors or heavy-duty castors with reinforcing frame.

Rear side of the cabinet

There are two cable entries on the rear wall of the cabinet covered with breakout panels. One is at the top and the other at the bottom edge of the cover. The other cable entries are on the ceiling and in the base of the cabinet.

Perforation of the skeleton

The RMA cabinets have a perforated skeleton to provide cooling air access to the installed technology. Cooling can be supported by the installation of fan units.

Bonding

All detachable parts are bonded together according to the requirements of the relevant standard.

Flex frame

(valid for 800mm wide cabinets) The system allows the installation of sliding rails in 19", 21" and 23" spans. Another option is to shift the 19" vertical rail spacing to one side to provide more space on the other side.

Middle pair of vertical rails

For enclosures deeper than 800 mm, a third pair of vertical rails for mounting the technology is supplied as standard. Thanks to their open profile, they do not restrict the installation of deeper equipment. Shorter devices can be mounted on the central vertical rail using different types of brackets (optional accessories).

Wide skeleton rails

The wide skeleton rails are designed for the additional installation of accessories, such as power distribution units or vertical cable management panels that do not occupy the 19" units inside cabinet. Thanks to the design, the power distribution panels do not limit the use of slide-out servers even in 600 mm wide cabinets.

Accessories in skeleton rails

The skeleton rails have mounting holes on the inner edges throughout their entire height. The holes are at the unit spacing of the vertical rails and can be used for mounting certain types of accessories.

OPTIONAL ACCESSORIES

RAC-VP-D5x-X1

Horizontal cable management panel. Installation in the skeleton (rail) of the cabinet.

RAX-VP-Vxx-X2

Vertical cable management panel. Installation in the cabinet skeleton rail.

Power distribution units

Possibility of installing the PDU in the skeleton rails of the cabinet using a bracket (optional accessory).

RAX-VP-Xxx-X1 Horizontal cable management

For cabinets with loads of higher than 500 kg, we recommend installing the horizontal cable management system in skeleton, which also acts as a reinforcement.

Swing frame

All 800mm wide RMA cabinets can be equipped with a swing frame with a load capacity of 150 kg. Maximum available depth of the 19" equipment is 330 mm.

DESCRIPTION, USAGE

- 19" free-standing cabinet with IP20 protection.
- Cabinet includes 4 adjustable vertical rails for device mounting (6 rails for cabinets deeper than 800 mm).
- **Cabinet construction:**
 - welded steel frame with removable side panels,
 - single or double doors in versions of solid metal, perforated (80 % and 86 % air permeability) or glazed with safety tempered glass 4 mm (they can be on the front or back of the cabinet),
 - ready for installation of vertical cable management panels and power distribution units including mounting brackets into the skeleton of the cabinet,
 - preparation for easy joining of cabinets into larger assemblies.
- Max. permissible load of the door is 20 kg.
- Min. thickness of the surface finish is 65 µm.
- These cabinets are intended for installation data and telecommunication devices and their distribution systems.
- The frame of the cabinet and all the removable parts (side and rear covers, doors...) are bonded with flexible cables that have to be properly fixed and inserted into connectors throughout the period of use of the cabinet.
- There is one M8 screw placed on the bottom part of the cabinet as a central earthing point..
- Cable openings covered with breakout-type blanking panels are placed in the top and the bottom part of the cabinet.
- The maximum recommended static load of the cabinet is 800 kg using levelling feet or a base.

ADDITIONAL INFORMATION

Operating conditions

- **Operating environment:**
 - the indoor environment,
 - the cabinet is not intended for outdoor installations and for installations in environment that can negatively influence the functionality of the cabinet and the mounted devices (e.g. environment with danger of explosion or humid and wet surroundings).
- **Must be protected against:**
 - mechanical damage,
 - improper handling,
 - a different usage than the cabinet is intended for.
- **Improper handling is especially:**
 - overloading (exceeding the maximum recommended load capacity),
 - installation of equipment that adversely affects the operation and function of the cabinet or installed equipment,
 - change of the construction or design of the cabinet.
- When using the RAX-MS-X81-X1 castor set for direct mounting on the cabinet (the height of the cabinet is increased by 108 mm), the maximum total load capacity must be observed including the weight of the cabinet:
 - 200 kg for type RMA, RZA 600 mm wide,
 - 400 kg for type RMA, RZA 800 mm wide.

- When using the RAX-RK-Xxx-X1 castor set with reinforcing frame (RAX-MS-X81-X1 castors included), the maximum total load capacity is 450 kg including the weight of the cabinet**. The height of the cabinet is increased by 111 mm. The specified load capacity is valid for both 600 and 800 mm cabinet widths.
- When using the RAX-RK-Dxx-X1 castor set with reinforcing frame (RAX-MS-X47-X1 castors included), the maximum total load capacity is 900 kg including the weight of the cabinet**. The height of the cabinet is increased by 158 mm. The specified load capacity is valid for both 600 and 800 mm cabinet widths.
- To guarantee stability, at least 65% of the load must be installed in the lower half of the cabinet height.
- The relevant standards* must be observed when taxiing with a loaded cabinet.

Installation of the cabinet

- To ensure the maximum recommended load capacity and stability, it is essential that the load is evenly distributed between the front and rear vertical rails.
- The cabinet must be placed on a level floor and adjust any differences using the levelling feet.
- To avoid dust penetration in the case where cables lead through some of the cable openings, it may be sealed with a brush and secured by the fringe edge (both are included in the delivery).

Environmental protection

- All parts are made of recyclable materials and after decommissioning the cabinet, it must be disposed of according to relevant regulations

Certificate and conformity

- This product is certified with TÜV SÜD Czech and fully in accordance with ČSN EN 62208 ed.2:2012(EN 62208:2011). Latest certificate is available at www.triton-racks.com/certificates.

** The load capacities of the castors are applicable for travel speed up to 4 km/h on level ground and smooth surface at ambient temperature in the range of 10-30 °C. All dimensions, load capacities and tolerances correspond to following standards: EN 12527-12533, DIN 7845.*

*** Total weight of the cabinet = weight of the cabinet itself + installed accessories + installed equipment.
Load capacity per wheel = Total weight of the enclosure / 3.*

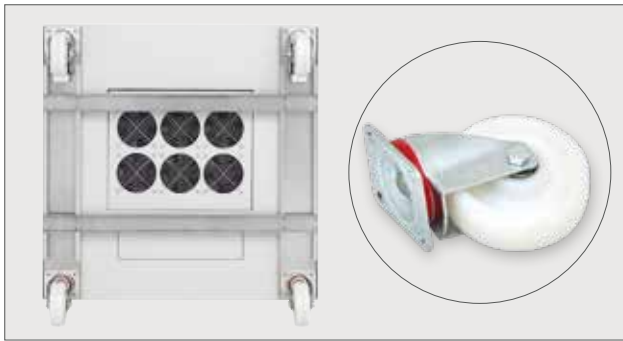

■ RAX-RK-Dxx-X1

Castors with reinforcing fram.

Castors with reinforcing frame for RMA, RZA, RTA, RYA, **RDA**, RDE type enclosures. Must be ordered according to the floor plan of the cabinet.

Max. recommended load capacity*:

- 900 kg for type RMA, RZA,

- **1050 kg** for type RTA, RYA, **RDA**, RDE.

The height of the cabinet is increased by 158 mm.

Set

Castors with a brake 2x

Castors without a brake 2x

Screw M5 x 12 Thorx 16x

Screw M5 x 20 Thorx 16x

Flat washer 5,3 16x

U-profile 4x

Cabinet depth (mm)	Cabinet width (mm)	
	600	800
600	RAX-RK-D66-X1	RAX-RK-D86-X1
800	RAX-RK-D68-X1	RAX-RK-D88-X1
900	RAX-RK-D69-X1	RAX-RK-D89-X1
1000	RAX-RK-D61-X1	RAX-RK-D81-X1
1100	RAX-RK-D60-X1	RAX-RK-D80-X1
1200	RAX-RK-D62-X1	RAX-RK-D82-X1

Swing frame

■ All 800 mm wide Triton cabinets can be equipped with a swing frame for mounting devices that require rear access. The swing frame reduces the usable height of the cabinet by 5U and can support up to 150 kg. The frame has two locks for securing it when closed. The distance of the swing frame from the cabinet doors

can be smoothly adjusted. The position of the frame affects the maximum usable depth of the mounted devices. When mounted in the optimal position, it can accommodate a 19" device with a depth of up to 300 mm. The swing frame can be mounted simultaneously with 19" verticals.

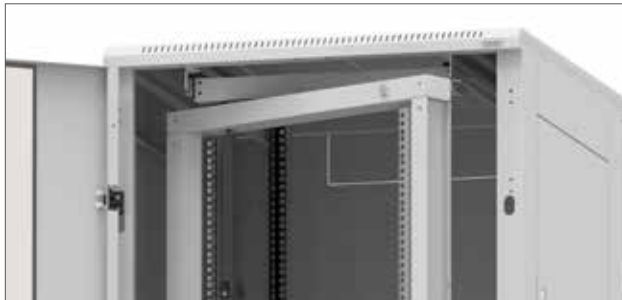

Swing frame	Cabinet height (U)	B (U) Usable frame height
RAC-VM-A17-A1	22	17
RAC-VM-A22-A1	27	22
RAC-VM-A27-A1	32	27
RAC-VM-A32-A1	37	32
RAC-VM-A37-A1	42	37
RAC-VM-A40-A1	45	40
RAC-VM-A42-A1	47	42

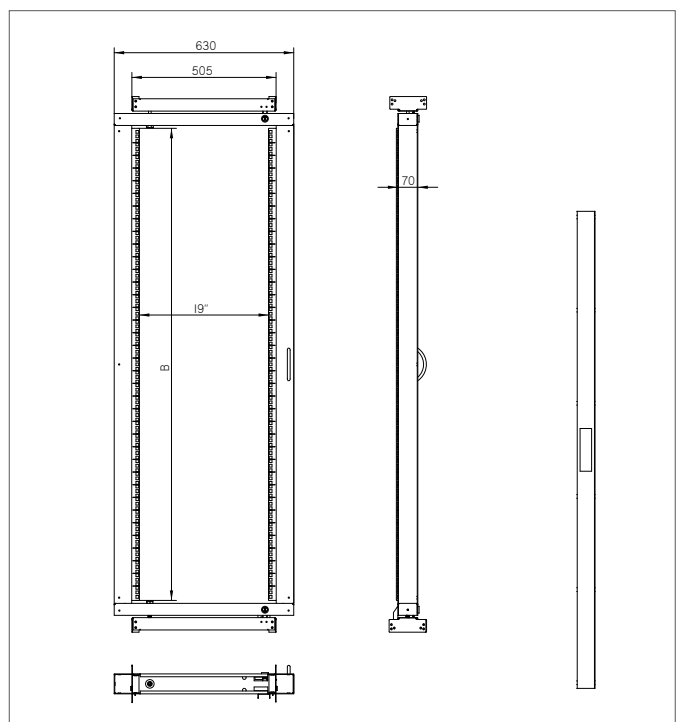

Variant A1

- with metal bottom,
- base, levelling feet and castors possible,
- side panels fixed by locks

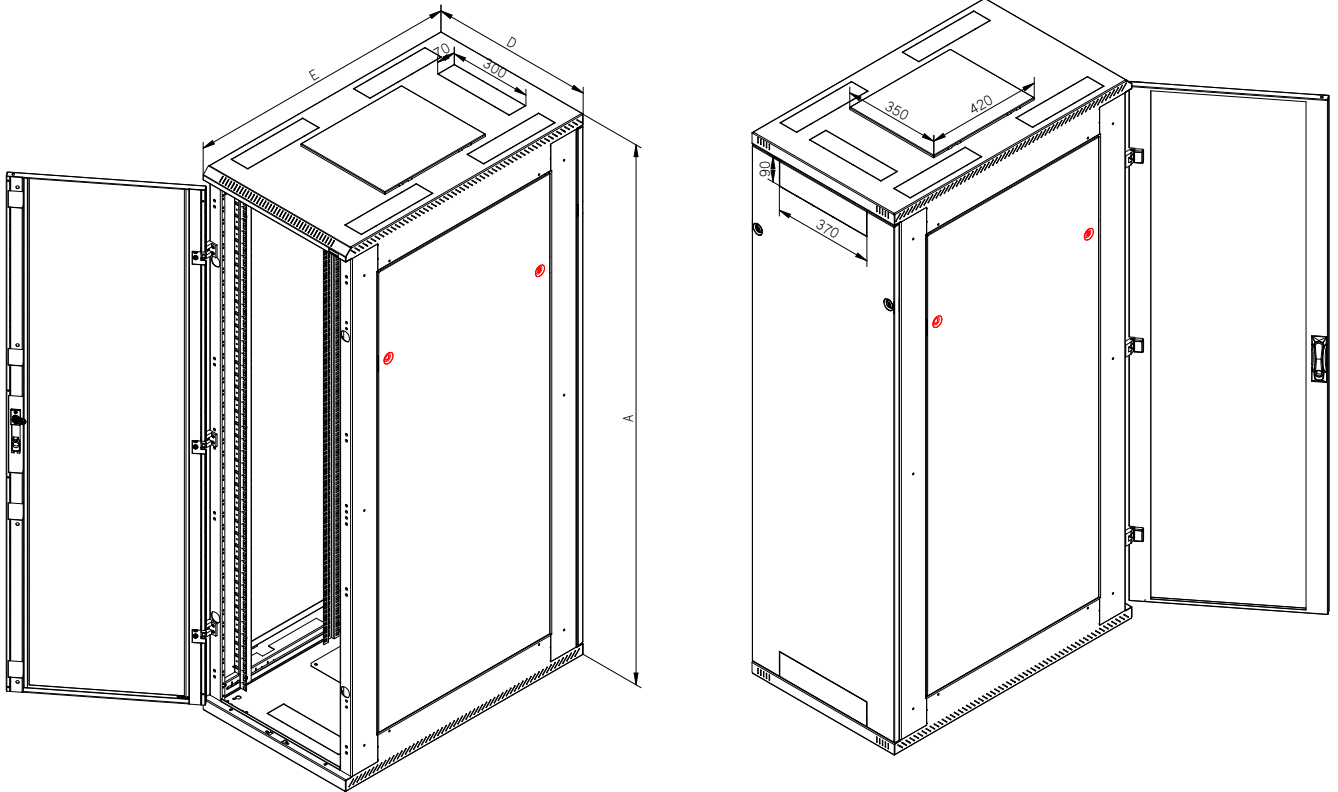

Variant A5

- with metal bottom
- base, levelling feet and castors possible
- side panels fixed by locks
- breakout cable entries in skeleton

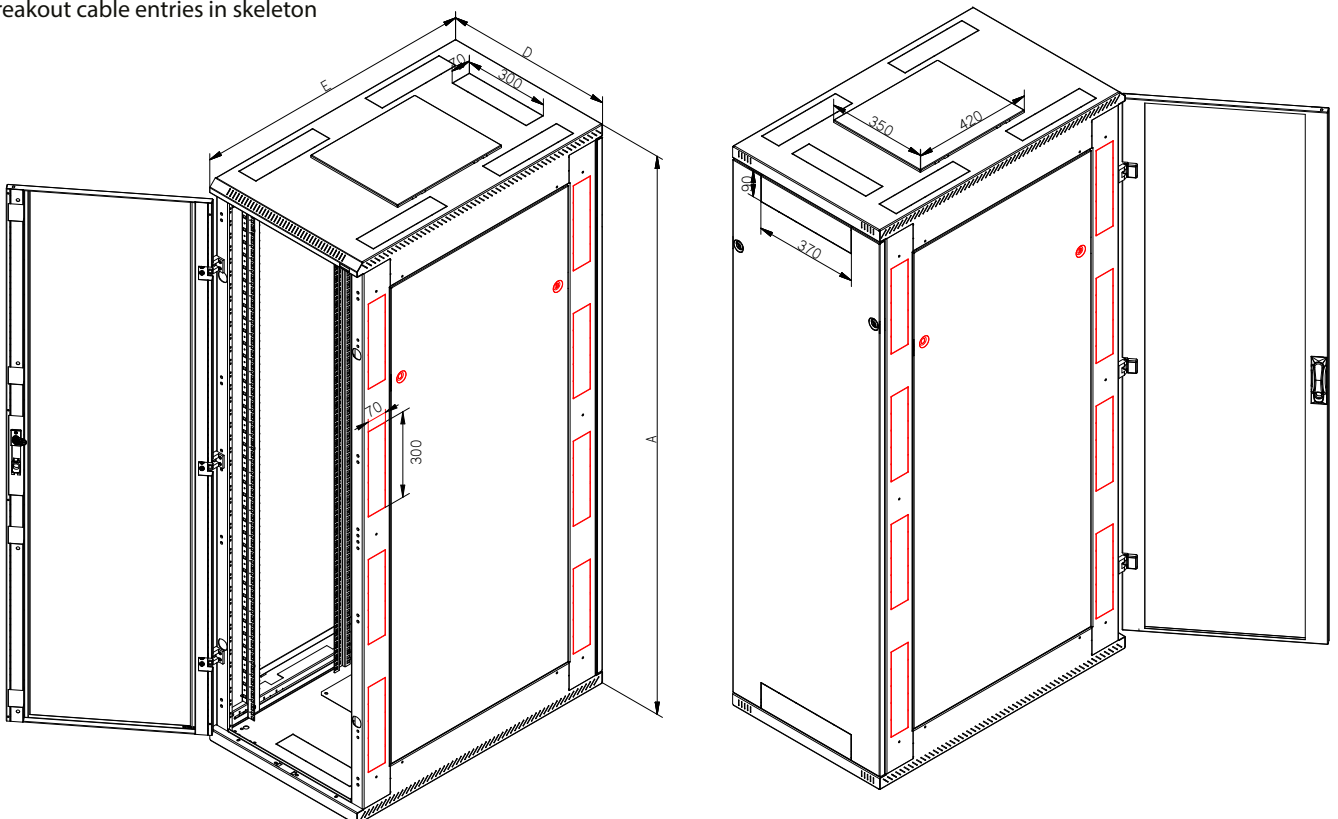

Variant A3 for data centers

- without metal bottom
- side panels fixed by recessed screws from the outside (from inside possible on request)

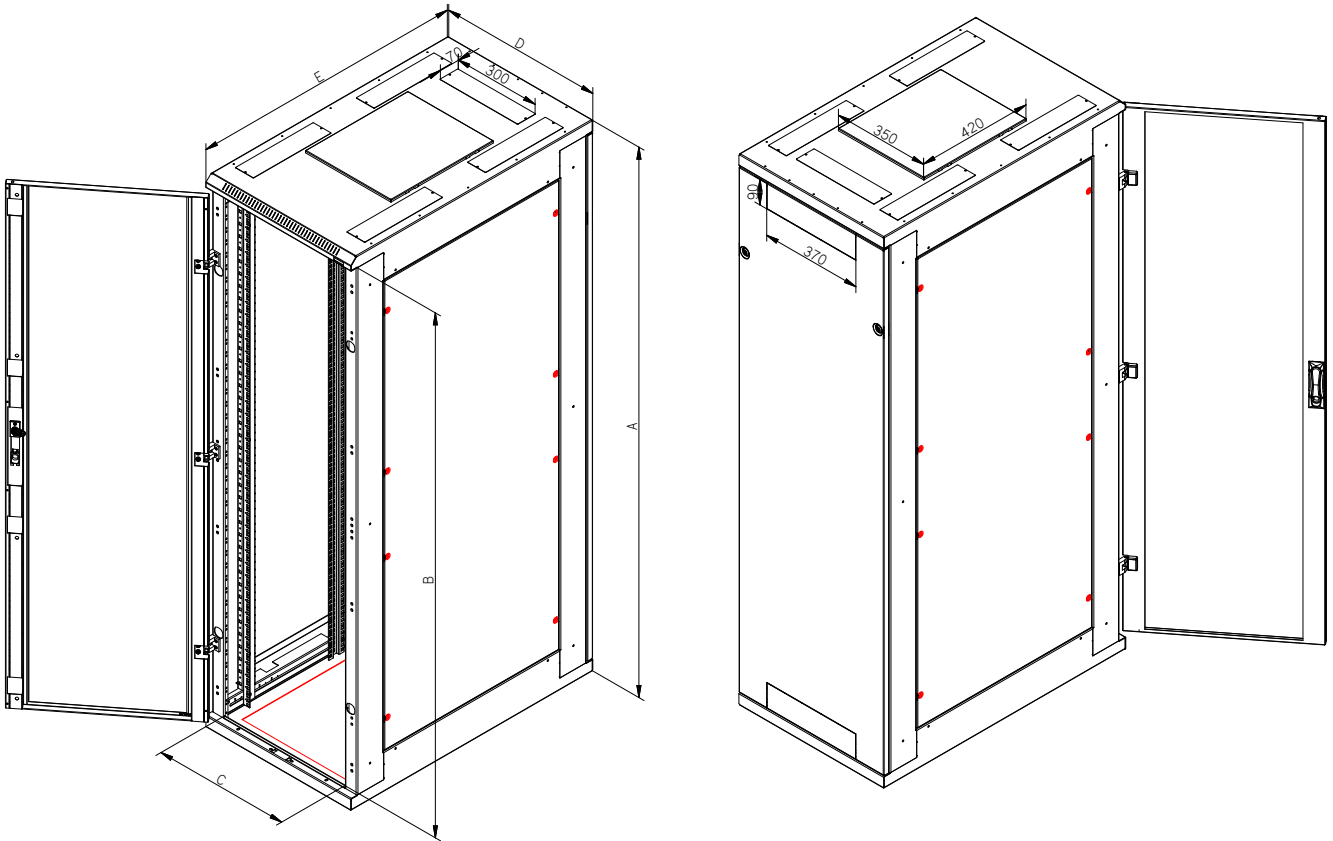

Variant A7 for data centers

- without metal bottom
- side panels fixed by recessed screws from the outside (from inside possible on request)
- breakout cable entries in skeleton

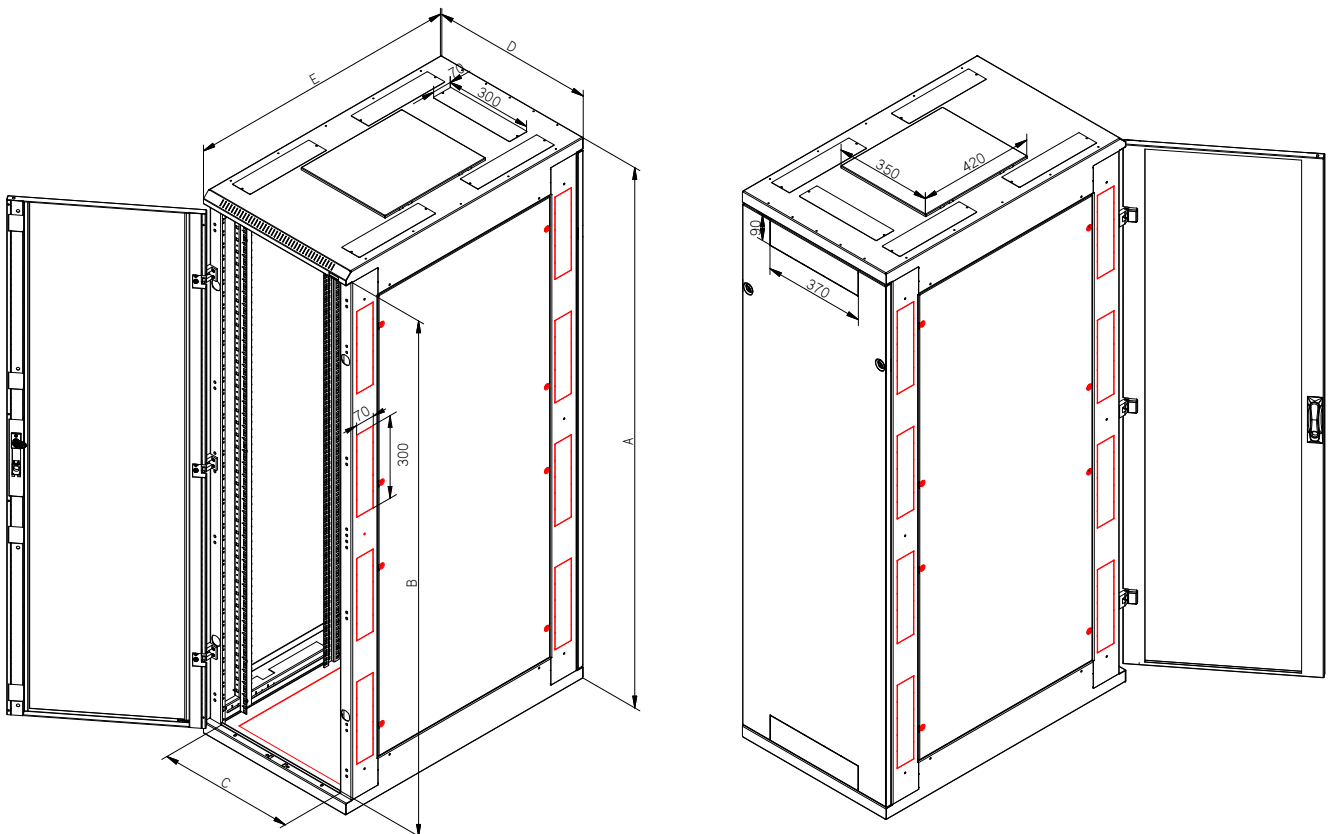

RDA free-standing cabinet

A universal cabinet for data and telecommunication purposes. High capacity for demanding applications, a large selection of sizes and options together with a wide selection of accessories and excellent development make it the best-selling cabinet in our range.

PRODUCT DETAILS

Rigid construction

The RDA has a robust welded construction that is made completely of 2 mm thick material. High quality workmanship and the latest technology ensure excellent look of the cabinet.

Flexible door opening

The hinge system allows the door to open 165°. The door can be easily removed and re-mounted to change the direction of opening. The double wing doors are equipped with hook-on hinges.

Tritón handles

We manufacture our own handles for the free-standing cabinets. By replacing the plastic module (not included), a half-cylindrical lock insert can be fitted. Patent: PUV 2013-27443

Adjustable vertical rails

Reinforced 19" vertical rails for higher load capacity can be infinitely adjusted at any depth of the cabinet. This simplifies mounting of the devices and the organisation of the patch cables.

Removable side panels and rear cover

The RDA is a cabinet with a welded skeleton, removable side panels and rear cover. Panels are attached to the skeleton by locks, as standard with a uniform key (variants A1 and A5). Variants A3 and A7 has panels secured by safety recessed screws.

Door for fan units

With this cabinet type, it is possible to order a special metal door ready for mounting RAX-CH-X0x-X3 fan units. Further information is available in the section Active cooling.

Break-out blanking panels

The cable entries of the cabinet are covered with break-out covers (variant A1 and A5). In the case of A3 and A7, the covers are screwed on. The cables in the opening can be sealed against the ingress of dust with a brush. To protect the cables from damage, a fringe edge is used (both supplied with the cabinet).

Opening for a fan unit

A large opening covered with a click-in blanking panel enables mounting and removal of the Triton fan unit from the outside of the cabinet without the need of using screws.

Castors, levelling feet, base

The cabinet can be placed on levelling feet (included) or, with optional equipment, on a base, castors or heavy-duty castors with reinforcing frame.

Rear side of the cabinet

There are two cable entries on the rear wall of the cabinet covered with breakout panels. One is at the top and the other at the bottom edge of the cover. The other cable entries are on the ceiling and in the base of the cabinet.

Perforation of the skeleton

The RDA cabinets have a perforated skeleton to provide cooling air access to the installed technology. Cooling can be supported by the installation of fan units.

Bonding

All detachable parts are bonded together according to the requirements of the relevant standard.

Flex frame

(valid for 800mm wide cabinets) The system allows the installation of sliding rails in 19", 21" and 23" spans. Another option is to shift the 19" vertical rail spacing to one side to provide more space on the other side.

Middle pair of vertical rails

For enclosures deeper than 800 mm, a third pair of vertical rails for mounting the technology is supplied as standard. Thanks to their open profile, they do not restrict the installation of deeper equipment. Shorter devices can be mounted on the central vertical rail using different types of brackets (optional accessories).

Wide skeleton rails

The wide skeleton rails are designed for the additional installation of accessories, such as power distribution units or vertical cable management panels that do not occupy the 19" units inside cabinet. Thanks to the design, the power distribution panels do not limit the use of slide-out servers even in 600 mm wide cabinets.

Accessories in skeleton rails

The skeleton rails have mounting holes on the inner edges throughout their entire height. The holes are at the unit spacing of the vertical rails and can be used for mounting certain types of accessories.

Skeleton rails on A5 and A7 versions

The "A5" and "A7" versions (at the end of the cabinet code) have in skeleton rails the cable entries with break-out covers to allow patch cords to be routed between the adjacent cabinets.

OPTIONAL ACCESSORIES

RAC-VP-D5x-X1

Horizontal cable management panel. Installation in the skeleton (rail) of the cabinet.

RAX-VP-Vxx-X2

Vertical cable management panel. Installation in the cabinet skeleton rail.

Power distribution units

Possibility of installing the PDU in the skeleton rails of the cabinet using a bracket (optional accessory).

Swing frame

All 800mm wide RDA cabinets can be equipped with a swing frame with a load capacity of 150kg. Maximum available depth of the 19" equipment is 330 mm.

DESCRIPTION, USAGE

- 19" free-standing cabinet with IP20 protection.
- Cabinet includes 4 adjustable vertical rails for device mounting (6 rails for cabinets deeper than 800 mm).
- **Cabinet construction:**
 - welded steel frame with removable side panels,
 - single or double doors in versions of solid metal, perforated (80 % and 86 % air permeability) or glazed with safety tempered glass 4 mm (they can be on the front or back of the cabinet),
 - ready for installation of vertical cable management panels and power distribution units including mounting brackets into the skeleton of the cabinet,
 - preparation for easy joining of cabinets into larger assemblies.
- Max. permissible load of the door is 20 kg.
- Min. thickness of the surface finish is 65 µm.
- These cabinets are intended for installation data and telecommunication devices and their distribution systems.
- The frame of the cabinet and all the removable parts (side and rear covers, doors...) are bonded with flexible cables that have to be properly fixed and inserted into connectors throughout the period of use of the cabinet.
- There is one M8 screw placed on the bottom part of the cabinet as a central earthing point..
- Cable openings covered with breakout-type blanking panels are placed in the top and the bottom part of the cabinet.
- The "A5" and "A7" versions have in skeleton rails the cable entries with break-out covers to allow patch cords to be routed between the adjacent cabinets.
- The maximum recommended static load of the cabinet is 800 kg using levelling feet or a base.

ADDITIONAL INFORMATION

Operating conditions

- **Operating environment:**
 - the indoor environment,
 - the cabinet is not intended for outdoor installations and for installations in environment that can negatively influence the functionality of the cabinet and the mounted devices (e.g. environment with danger of explosion or humid and wet surroundings).
- **Must be protected against:**
 - mechanical damage,
 - improper handling,
 - a different usage than the cabinet is intended for.
- **Improper handling is especially:**
 - overloading (exceeding the maximum recommended load capacity),
 - installation of equipment that adversely affects the operation and function of the cabinet or installed equipment,
 - change of the construction or design of the cabinet.
- When using the RAX-MS-X47-X1 castor set for direct mounting on the cabinet (the height of the cabinet is increased by 155 mm), the maximum total load capacity must be observed including the weight of the cabinet:
 - 500 kg for type RTA, RYA, RDA, RDE 600 mm wide,
 - 600 kg for type RTA, RYA, RDA, RDE 800 mm wide.